



Heating and Cooling

CAHV Low-GWP Heat Pump Water Heater

PRODUCT CATALOGUE



CAHV-R136YAU(-BS)

- ▶ Low GWP (148)
- ▶ Operates down to -25 °C
- ▶ Modular design
- ▶ High-efficient inverter technology

R-454C

ecodan®

MitsubishiElectricCAHV.ca

Renewable Heating Technology

Given today's concerns about global warming, environmental protection efforts are becoming increasingly stringent. The Kigali Amendment to the Montreal Protocol, is an international agreement set to phase down the production and consumption of HFCs by 80-85% by 2047.

The Mitsubishi Electric CAHV air source heat pump uses low-GWP R454C refrigerant - The sustainable solution for modular hydronic heating and domestic hot water.

Features

1. Low-GWP refrigerant

With the demand for low-GWP refrigerant accelerating in North America, the CAHV uses a R454C refrigerant with a low global-warming potential (GWP) of 148, 93% lower compared to using R410A.

2. Low running costs & wide operating temperature range

Hot water heat pumps absorb energy from the surrounding outdoor air and transfer it into refrigerant. Heat energy absorbed from the air heats up the incoming water via the heat exchanger. The Coefficient of Performance (COP) of the new CAHV is 2.85 which means it can extract almost three times the electric energy input.

Hot water heat pump system

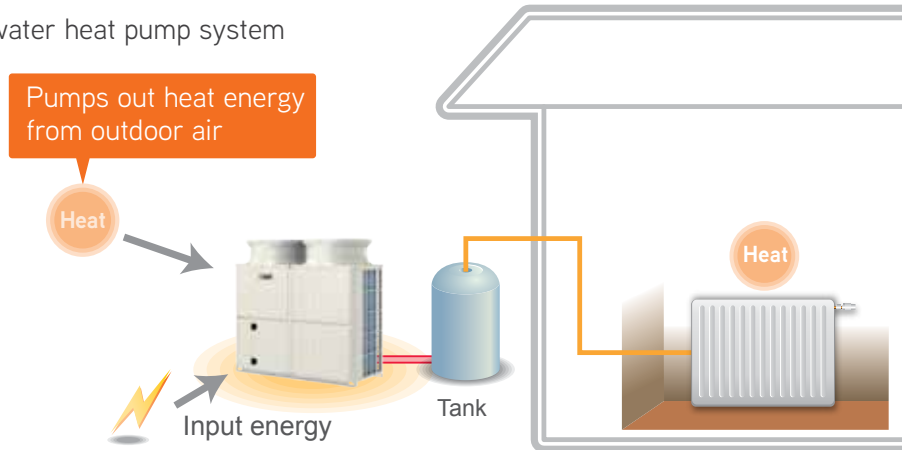

The hot water heat pump can be operated at outdoor temperatures between -25°C and 43°C. 74°C hot water output is possible down to -10°C outdoor temperature. It delivers precise comfort through all seasons.

Range of operation temperature and outlet water temperature

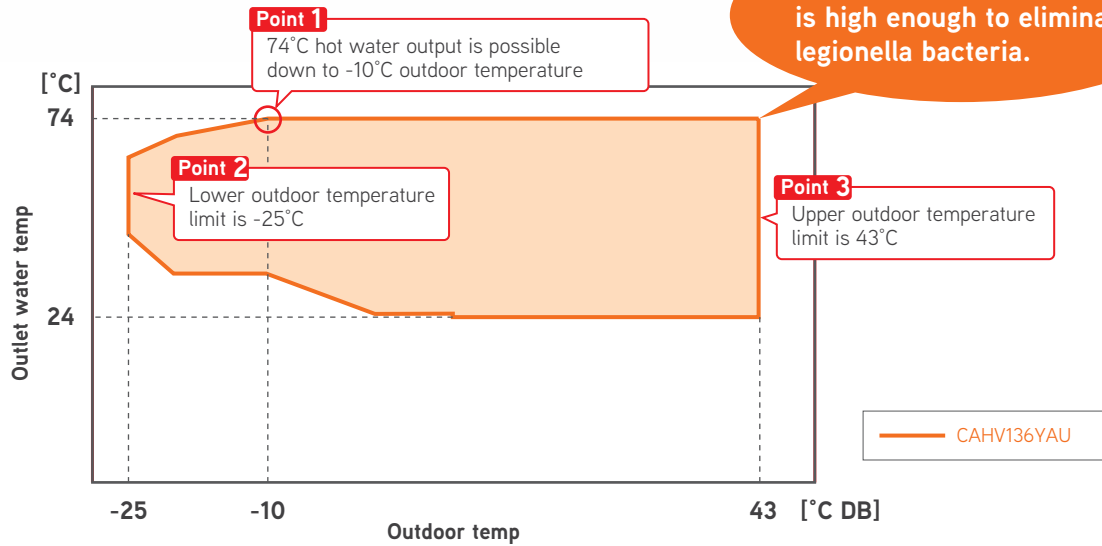

The 70°C output water is high enough to eliminate legionella bacteria.

Various Applications

Community Complexes



Comfort heating applications such as radiators and underfloor heating in housing complexes.

Hospitality & Recreational Centers



Comfort heating and thermal applications such as showers and swimming pools in hotels and health centers.

Industrial Facilities



For applications with high heat-retention loads, such as parts washing and painting lines. The CAHV can also meet high horsepower demands by combining several units.

Award History

The R454C CAHV was launched in the European market in 2023 and has won multiple industry awards. Mitsubishi Electric is proud to receive this recognition for the product excellence of the CAHV commercial air source hot water heat pump, which is designed to help businesses decarbonize their heating as we move to Net Zero.



National ACR & Heat Pump Awards 2023

Heat Pump Product of the Year*
* Awards received in the UK.



RAC Cooling Industry Awards 2023

Innovation of the Year*
* Awards received in the UK.



HVR AWARDS

Commercial / Industrial Heat Pump Product of the Year*
* Awards received in the UK.

3. Low maintenance & design flexibility

Clean and safe

The hot water heat pump system runs on electricity only. It does not require the safety measures and periodic inspections required for gas and other combustion appliance-mounted systems, and does not generate toxic substances such as NOx.

Rotation function

When two or more units are in the system, the unit runs alternately, ensuring an optimum product lifecycle for both component units. No external control source needed. Integrable with other City Multi systems via M-NET.

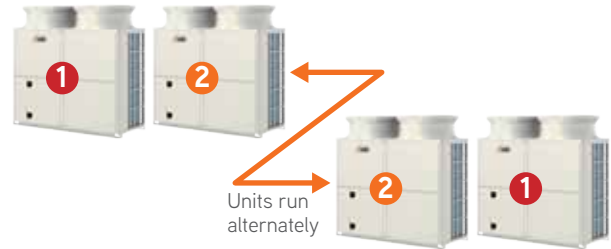

Multi-unit installation

The number of outdoor units can be adjusted from 1 to 16 according to the tank storage capacity.

Up to 16 units can be connected to one tank.

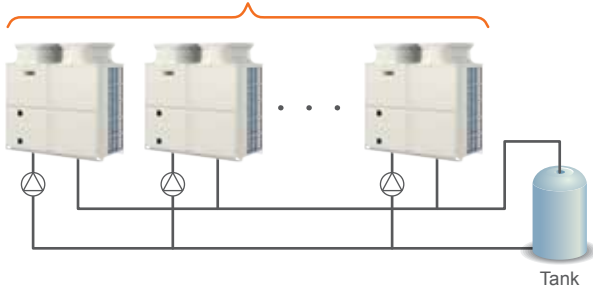

Monobloc multi-pass

The unit is self-contained with all of the components situated within the unit chassis resulting in simple installation and low maintenance.

Wide variety of external input / output

- Various system configurations are available.
- Two external output for backup heater
 - Analog input to control capacity
 - Defrost signal
- * Refer to the Data Book for other functions.

Key technologies

Refrigerant circulation and pressure control with two LEVs

The R454C refrigerant is a lower pressure refrigerant than R407C and R410A, which is commonly used in air conditioners. Because low-pressure refrigerants have a low refrigerant density, securing circulation volume can be challenging especially when the refrigerant circuit pressure drops due to low outdoor temperatures or other conditions.

Linear expansion valves (LEVs) before heat exchanger (HEX) were increased from one to two and placed in parallel. The opening of LEV1 focuses on securing the refrigerant circulation volume. LEV3 manages the refrigerant pressure. Each are controlled respectively to maintain refrigerant circulation.

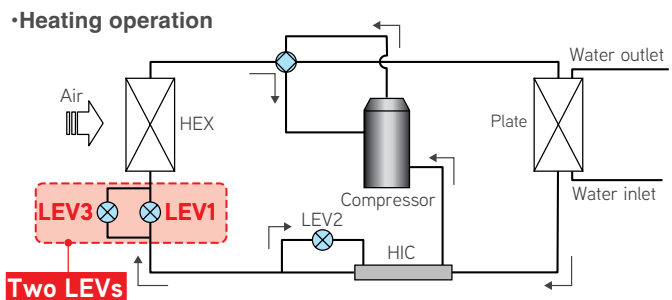

New compressor has been developed

Highlights of the new compressor

- ✓ Spiral structure
- ✓ Flash injection circuit
- ✓ Inverter frequency control

Compatible with R454C refrigerant



Spiral structure

The low density of R454C refrigerant requires an increased amount of refrigerant to be discharged from the discharge section. The new compressor uses a new material for the fixed spiral section, which enables the tooth to be thinner while maintaining their strength. The height of the teeth has also been lengthened. This synergistic effect has resulted in a 15% increase in the extrusion volume from the discharge section compared to the conventional model (assuming the scroll section of the old and new compressors have the same volume).

Spiral design with equal tooth thicknesses used in the conventional compressors

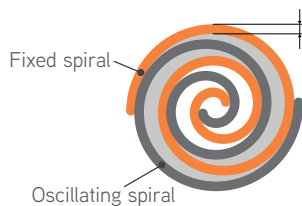

New spiral design with different tooth thicknesses for CAHV

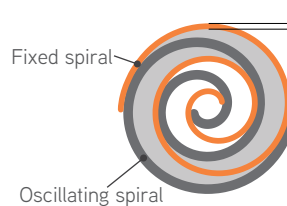

NEW
A thinner tooth with stronger material

Flash injection circuit

The flash injection circuit is a Mitsubishi Electric technology used in air conditioners for cold climates. The CAHV also adopts this circuit to help units produce high-temperature water even at low outdoor temperatures.

Liquid refrigerant, whose pressure is reduced by the LEV2, exchanges heat in the HIC circuit and becomes a gas-liquid two-phase refrigerant. This two-phase refrigerant flows into the injection port in the compressor and controls the increase of the discharge temperature. Therefore the optimal amount of refrigerant can be provided to the system via the compressor.

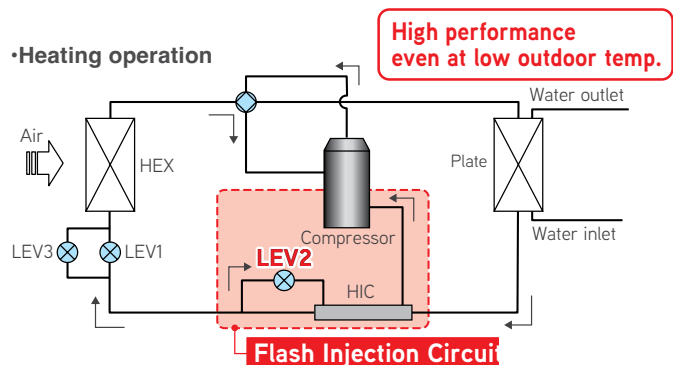

Inverter frequency control

The new compressor is driven by an inverter, allowing operation at lower capacity. This helps minimize thermo ON/OFF frequency during low-load operations, such as in intermediate seasons, and improves energy efficiency.

Controller

Individual remote controller

•PAR-W31MAA

PAR-W31MAA offers an easy-to-see full-dot and backlit LCD display. Basic operations, such as ON/OFF, mode switching, water temperature setting and schedule setting, can be performed. Up to 16 units can be controlled with one remote controller.



Major functions

| | |
|-----------------------|--|
| Operation/ setting | ON/OFF |
| | Hot water/Heating/HeatingECO/Anti-freeze |
| | Snow/regular |
| | Demand |
| Display | Scheduled operation (daily/weekly) |
| | Operation mode |
| | Current water temperature |
| | Error code |

Centralized remote controller

•AE-C400A / EW-C50A

The CAHV-R136YAU(-BS) is connectable to the AE-C400A that centrally controls up to 50 units or 50 systems connected via M-NET.

Major functions

| | |
|-----------------------|---|
| Operation/ setting | ON/OFF |
| | Hot water/Heating/HeatingECO/Anti-freeze |
| | Snow/regular |
| | Scheduled operation (daily/weekly/annual) |
| Display | Operation mode |
| | Current water temperature |
| | Error code |

System configuration

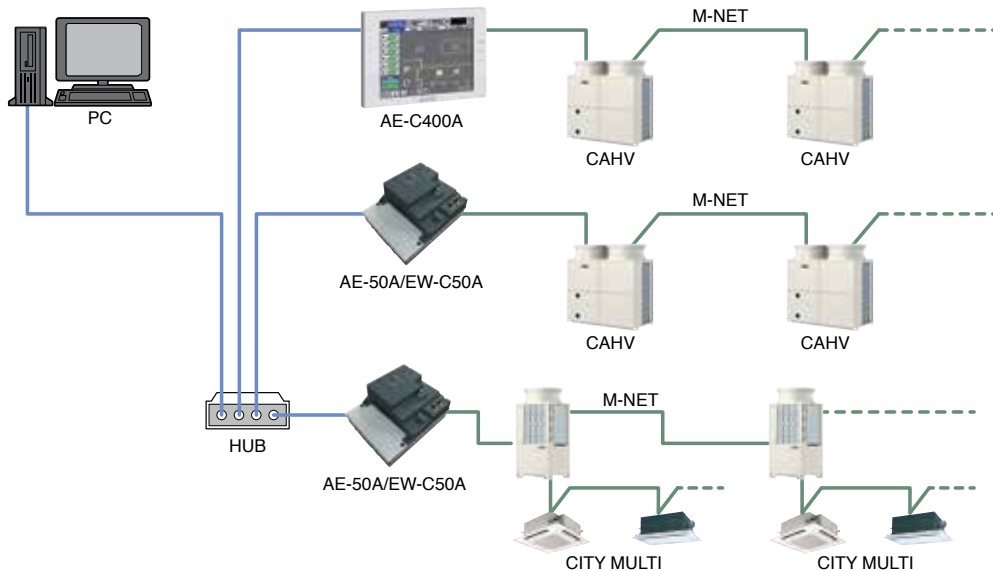

Optional parts

| Description | Model |
|---|-----------|
| Y type STRAINER 40A | YS-40A |
| Representative water temperature sensor | TW-TH16-E |

Specifications

| Model | | CAHV-R136TAU (-BS) | CAHV-R136YAU (-BS) | |
|--|-------------------------------|--|---|--|
| Power source | | 3-phase 3-wire 208-230 V 60 Hz | 3-phase 3-wire 460 V 60 Hz | |
| Capacity(EN14511) *1 | kW | 40.0 | | |
| | BTU/h | 136,480 | | |
| | Power input kW | 14.03 | | |
| | Current input | A | 208V : 43.3 | 460V : 19.6 |
| | | A | 230V : 39.2 | |
| COP (kW/kW) | | 2.85 | | |
| Maximum current input | | A | 72.2 | |
| Water pressure drop *1 | | kPa(psi) | 10.2 (1.47) | |
| Temperature range *3 | Outlet water temperature | °C (°F) | 24-74 (75-165) | |
| | Outdoor temperature (D.B.) | °C (°F) | -25-43 (-13-109) | |
| Circulating water volume range*6 | | m³/h(G/h) | 4.0-15.0 (1056.8-3963.0) | |
| Sound pressure level (measured 1 m below the unit in an anechoic room) *1 *5 | | dB (A) | 65 | |
| Sound pressure level (measured 1 m below the unit in an anechoic room) *2 *5 | | dB (A) | 72 | |
| Water pipe diameter and type | Inlet | mm (in) | 40A (1-1/2 B), housing type joint | |
| | Outlet | mm (in) | 40A (1-1/2 B), housing type joint | |
| External finish | | Acrylic painted steel sheet <Munsell 5Y 8/1 or similar> | | |
| External dimensions H × W × D | | mm (in) | 1650 × 1750 × 740 (64-31/32 × 68-29/32 × 29-5/32) | |
| Net weight | | kg (lbs) | 362 (798) | |
| Design pressure | R454C | MPa(psi) | 3.85 (558) | |
| | Water | MPa(psi) | 1.0 (145) | |
| Drawing number | Wiring | | KW94R804 | |
| | External appearance | | KW94L288 | |
| Heat exchanger | Water-side | | Copper brazed stainless steel sheet | |
| | Air-side | | Plate fins and copper tubes | |
| Compressor | Type | | Inverter scroll hermetic compressor | |
| | Manufacturer | | MITSUBISHI ELECTRIC CORPORATION | |
| | Starting method | | Inverter | |
| | Motor output | kW | 12.1 | |
| | Lubricant | | FVC32EA | |
| Fan | Air flow rate | m³/min | 150 × 2 | |
| | | L/s | 2500 × 2 | |
| | | cfm | 5297 × 2 | |
| | External static pressure | | | 10 Pa (1 mm H ₂ O) |
| | Type and quantity | | | Propeller fan × 2 |
| | Control and driving mechanism | | | Inverter control, direct driven by motor |
| Motor output | | W | 920 × 2 | |
| HIC (Heat inter-changer) circuit | | | Copper pipe | |
| Protection devices | High pressure | | High-pressure sensor and switch set at 3.85 MPa (558 psi) | |
| | Inverter circuit | | Overheat and overcurrent protection | |
| Defrosting method | | | Auto-defrost mode (Reversed refrigerant cycle) | |
| Refrigerant | Type and factory charge | kg(lbs) | R454C. 9.0 (19.8) | |
| | GWP *4 | | 148 | |
| | Flow and temperature control | | LEV and HIC circuit | |
| SCCR | | kA | 5 | |

*1 Under normal heating conditions at the outdoor temperature of 7°CDB/6°CWB (44.6°FDB/42.8°FWB), the outlet water temperature of 45°C (113°F) and the inlet water temperature of 40°C (104°F). Tolerance of capacity and COP is based on AHRI 551/591.

*2 Under normal heating conditions at the outdoor temperature of 7°CDB/6°CWB (44.6°FDB/42.8°FWB) when the unit is set to the "Capacity Priority" mode through the dry NC-contact.

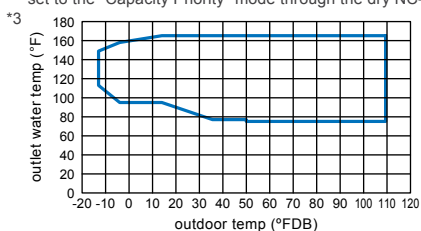

Outdoor temp. -25°CDB/Outlet water temp. 45~65°C (Outdoor temp. -13°FDB/Outlet water temp. 113~149°F)
 Outdoor temp. -20°CDB/Outlet water temp. 35~70°C (Outdoor temp. -4°FDB/Outlet water temp. 95~158°F)
 Outdoor temp. -10°CDB/Outlet water temp. 35~74°C (Outdoor temp. 14°FDB/Outlet water temp. 95~165°F)
 Outdoor temp. 43°CDB/Outlet water temp. 24~74°C (Outdoor temp. 109°FDB/Outlet water temp. 75.2~165°F)

* Stops operation at the outdoor temperature of -28°C (-18°F) or below CAHV-R136TAU (-BS)
 * Stops operation at the inlet water temperature of 72°C (161.6°F) or above CAHV-R136YAU (-BS)
 * Stops operation at the inlet temperature of 72°C (161.6°F) or above

*4 IPCC 4th assessment report

*5 The sound pressure level is a value measured in an anechoic room in accordance with the conventional method in JRA4060.

*6 The fluctuation of the flow rate must be 10% per minute or less.

• Due to continuing improvements, specifications may be subject to change without notice.

- Do not use steel pipes as water pipes.
- Keep the water circulated at all times. Blow the water out of the pipes if the unit will not be used for an extended period of time.
- Do not use ground water or well water.
- Do not install the unit in an environment where the wet bulb temperature exceeds 32°C (90°F).
- The water circuit must be a closed circuit.

Safe handling of R454C

R454C refrigerant properties

Under the conditions shown below, there is a possibility that R454C could burn.

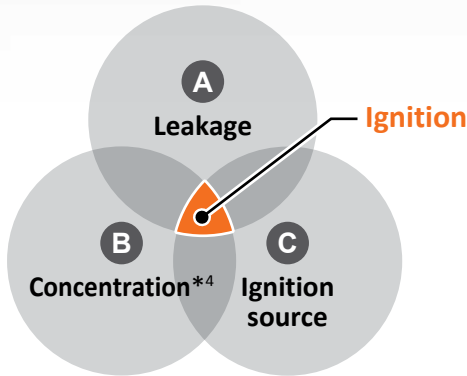

| | R454C |
|----------------------------------|--|
| Chemical formula | CH ₂ F ₂ /C ₃ H ₂ F ₄ |
| Composition (blend ratio wt. %) | R32/R1234yf (21.5/78.5 wt%) |
| Ozone depletion potential(ODP) | 0 |
| Global warming potential(GWP) *1 | 148 |
| LFL(kg/m ³) *2 | 0.293 |
| Flammability *3 | Lower flammability(2L) |

*1 IPCC 4th assessment report

*2 LFL : Lower flammable limit EN 378-1:2016+A1:2020

*3 IEC60335-2-40 : 2018

*4 R454C consistency is higher than LFL and lower than UFL.

Be sure to observe the following three points to use R454C safely.

WARNING

A Do not leak refrigerant.

<Installation>

- Vacuum drying should be done. Do not release refrigerant into the atmosphere unnecessarily.
- Follow "Installation points of charging refrigerant."

<Repair/Removal>

- Refrigerant should be recovered.

B Prevent concentration.

- Follow "Installation restrictions."

C Keep ignition sources away from the unit.

- Do not braze pipes that contain refrigerant. Before brazing, refrigerant should be recovered.
- Do not install the unit while electricity is on. Turn off electricity and check using a tester.
- Do not smoke during work and transportation.

Note: R454C emit toxic gas when exposed to naked flame.

Installation restrictions

General restrictions



Do not install the unit where combustible gas may leak.

- If combustible gas accumulates around the unit, fire or explosion may result.

- Provide sufficient space around the unit for effective operation, efficient air movement, and ease of access for maintenance.
- All restrictions mentioned in this manual apply not only to new installations but also to relocations and layout changes.
- Refer to the Installation manual for other precautions on installation.
- Appliance shall install to secured location with restricted access
(e.g. location of not accessible to the general public, like a rooftop and fence guard etc...)

Installation space requirement

- Do not install the unit inside a building such as the basement or machine room, where the refrigerant may stagnate.
- Install the unit in a place where at least one of four sides is open.

Figure 1

Correct installation

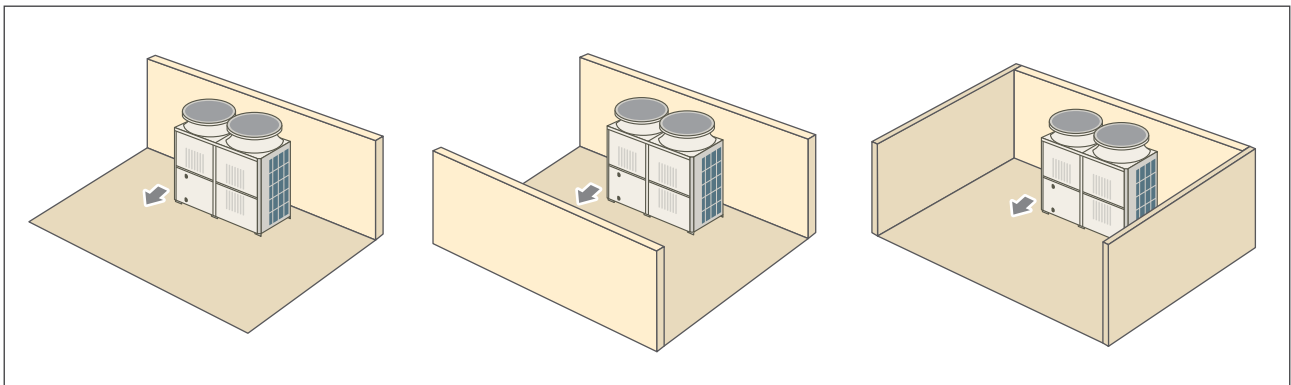

Incorrect installation

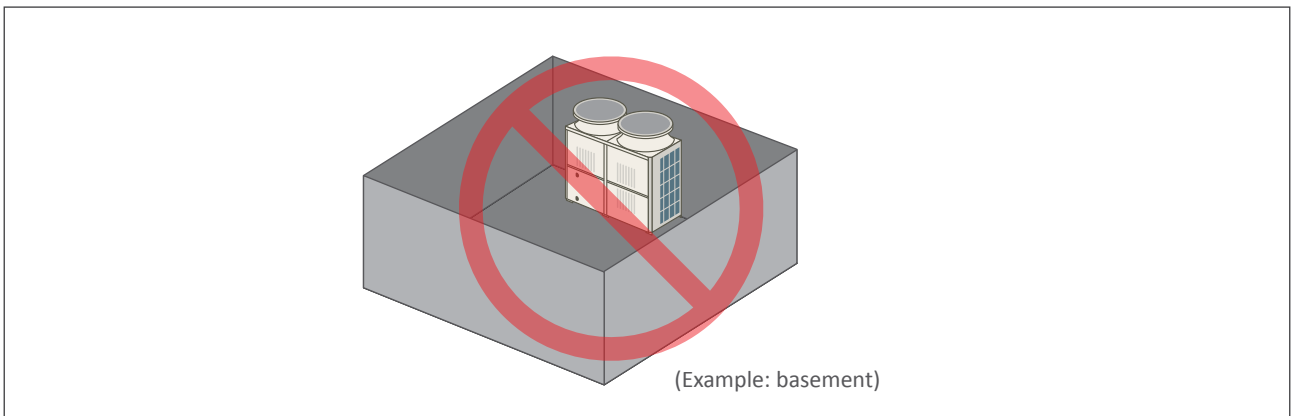

If the unit needs to be installed in a space where all four sides are blocked, confirm that one of the following situations (A or B) is satisfied.

A. Install the unit in a space with a wall height of ≤ 0.125 m.

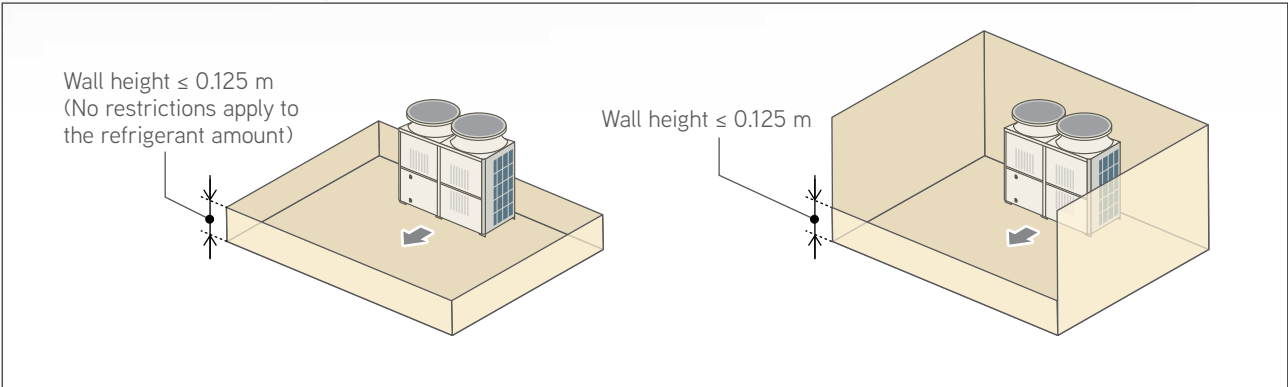

B. Create an appropriate ventilation opening.

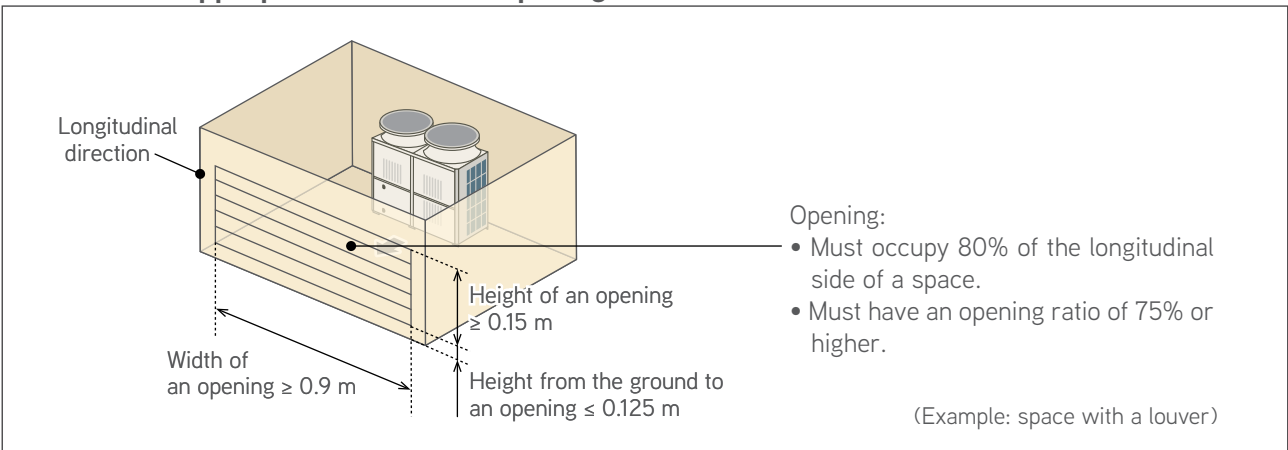

Regulatory requirements for safety

See below for information on installing a safety device on the CAHV hot water heat pump system.

* Safety devices shall be regularly inspected, maintained, and replaced in accordance with relevant laws, regulations, and the instructions of the manufacturers.

* The requirements listed below were established based on IEC60335-2-40 (Edition 6.0) G.G.6. See the original standards for further information on selecting a safety device.

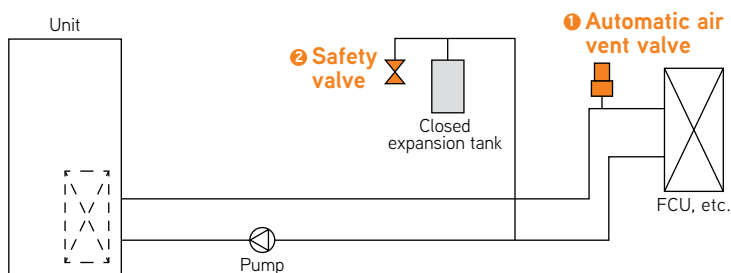

Required items

- ① Automatic air vent valve
- ② Safety valve

Note

* In the event of a failure of the waterside heat exchanger in the unit, the refrigerant may leak from the automatic air vent valve or safety valve, so install it in a place where the refrigerant will not accumulate, such as outdoors.

WARNING

- Do not use refrigerant other than the type indicated in the manuals provided with the unit and on the nameplate.
 - Doing so may cause the unit or pipes to burst, or result in explosion or fire during use, repair, or at the time of disposal of the unit.
 - It may also be in violation of applicable laws.
 - MITSUBISHI ELECTRIC CORPORATION cannot be held responsible for malfunctions or accidents resulting from the use of the wrong type of refrigerant.
- Our air-cooled Condensing Units contain a fluorinated greenhouse gas, R454C (GWP:148). This GWP value is based on Regulation (EU) No. 517/2014 from IPCC 4th edition.

Environmental Sustainability Vision 2050

Protect the air, land and water with our hearts and technologies to sustain a better future for all.



To solve various factors that lead to environment issues, the Mitsubishi Electric Group shall unite the wishes of each and every person, and strive to create new value for a sustainable future.

R-454C

ecodan[®]

MitsubishiElectricCAHV.ca